

Kazakhstan china electric vehicle market

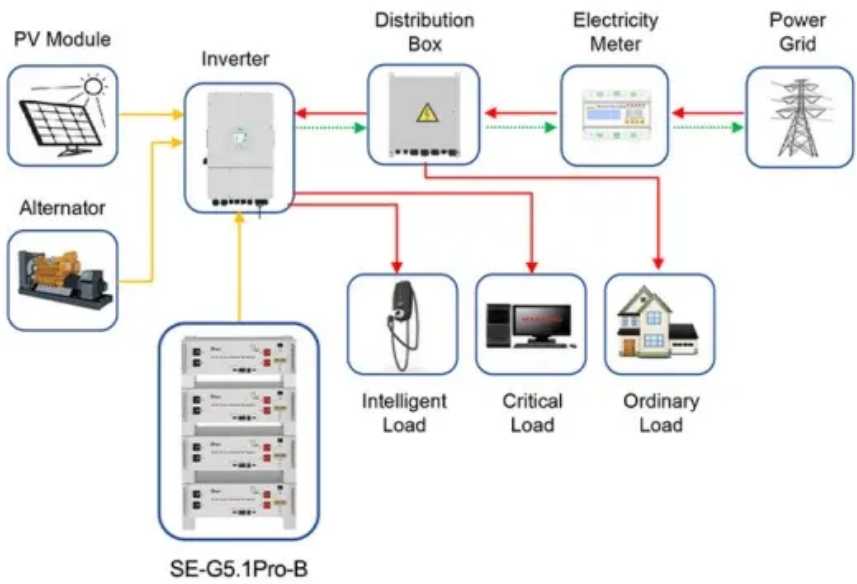

Application scenarios of energy storage battery products



Overview

Kazakhstan's EV market surges 60% in a year, driven by duty-free imports and rising Chinese EV popularity. Almaty leads registrations with 7,309 vehicles.

Kazakhstan china electric vehicle market



Kazakhstan , Eurasianet

Uzbeks and Kazakhs among most charitably inclined peoples globally - report Charitable activity increasing steadily in Kazakhstan.



About Kazakhstan

Kazakhstan is a leader in Central Asia, actively facilitating the strengthening of stability and security in the region. The country has achieved significant success on the world stage, which is evidenced by



Kazakhstan

Kazakhstan is the world's ninth-largest country by land area and the largest landlocked country. Hilly plateaus and plains account for nearly half its vast territory, with lowlands composing another third;



[Where is Kazakhstan? Culture, Facts & Travel](#)

Discover Kazakhstan. Explore Kazakhstan facts, culture, history & comprehensive country profile with maps, statistics & research resources for students & travelers.



[China fuels global EV surge as Kazakhstan accelerates](#)

China's dominance is rooted in strategic advantages: generous government subsidies, a mature supply chain, and a deep talent pool. As

a

[Kazakhstan , History, Culture, Facts, Map, & People , Britannica](#)

Kazakhstan is the largest country in Central Asian and a former part of the Soviet Union. It has great mineral resources and abundant arable land.



Why China Is So Interested in Kazakhstan

Kazakhstan has many of them, and China, the biggest producer of electric vehicles and batteries, is right next door and eager to buy. "Everything is

Kazakhstan Maps & Facts

Kazakhstan is a transcontinental country with major parts in Central Asia and a small part in Eastern Europe. It is located in the Northern and Eastern hemispheres of the Earth (at the junction



[Kazakhstan in China's EV Playbook: Market Boom Without](#)

Chinese electric vehicle sales are surging in Kazakhstan thanks to favorable policies and price-performance appeal, but major manufacturers remain reluctant to set up local production.

Kazakhstan

Kazakhstan facts: Official web sites of Kazakhstan, links and information on Kazakhstan's art, culture, geography, history, travel and tourism, cities, the capital city,



airlines, embassies, tourist boards and



[Electric Vehicles in Kazakhstan: What is already available and what is](#)

In conclusion, the development of the electric vehicle sector in Kazakhstan requires a comprehensive approach, including the adoption of appropriate legislation to encourage investment

Kazakhstan

Kazakhstan, officially the Republic of Kazakhstan, is a country that is bigger than Western Europe, and stretches over a vast expanse of northern and central Eurasia to the west of the Ural River.



[Electric Vehicles in Kazakhstan: Growth, Gaps, and the Road Ahead](#)

Kazakhstan's EV market has increasingly aligned with global trends, particularly the dominance of Chinese manufacturers. Today, around 70% of EVs in the country are made in China,



[Kazakhstan Travel Guide: Costs, Visa, Safety & Local Tips \(2026\)](#)

Plan your Kazakhstan trip: visa-free for 77 countries, \$30-50/day budget, Almaty to steppe. Real costs, safety data, and local insights from a Kazakh guide.



[Kazakhstan sees electric vehicle sales soar with 60%+ growth](#)

A notable trend in Kazakhstan's electric vehicle market is the increasing share of Chinese-made

EVs. According to the Kazakhstan Automobile Union, the market share of Chinese

The Ultimate 2026 Importer's Guide to Kazakhstan car import from China

Master Kazakhstan car import from China in 2026: Navigate new EV export licenses, EAEU homologation & rail logistics. Get exact landed costs & compliance strategies.



[China Expanding into Kazakhstan's EV Charging Market:](#)

As Kazakhstan pushes toward green energy transition (per its Carbon Neutrality 2060 target), the electric vehicle (EV) market is experiencing exponential growth. In 2023, EV registrations surpassed

[The Best Guide to Travel in Kazakhstan: 18 things you should know to](#)

This is the most complete and updated online guide to travel in Kazakhstan. If you find yourself fascinated by this vast, beautiful country and love unusual destinations, this travel guide will



[How kazakhstan's ev policies are reshaping the kazakhstan ev market](#)

Kazakhstan's combination of bold targets, expanding infrastructure, grid readiness, and public transport modernisation is forging a solid roadmap for the Kazakhstan EV market.

[Central Asia: China in driver's seat of foreign car sales](#)

Import statistics for 2023 show that Chinese automakers have blown past foreign competitors to become the dominant player in Central Asia's foreign



Contact Us

For catalog requests, pricing, or partnerships, please visit:
<https://european-startups.eu>